

**ARMY TM 5-810-4
AIR FORCE AFM 88-8, Chap. 3**

COMPRESSED AIR

**DEPARTMENTS OF THE ARMY, AND THE AIR FORCE
12 JANUARY 1990**

REPRODUCTION AUTHORIZATION/RESTRICTIONS

This manual has been prepared by or for the Government and, except to the extent indicated below, is public property and not subject to copyright.

Copyrighted material included in the manual has been used with the knowledge and permission of the proprietors and is acknowledged as such at point of use. Anyone wishing to make further use of any copyrighted material, by itself and apart from this text, should seek necessary permission directly from the proprietors.

Reprints or republications of this manual should include a credit substantially as follows: "Joint Departments of the Army and Air Force, USA, Technical Manual TM 5-810-4/AFM 88-8, Chapter 3, Compressed Air, 12 January 1990."

If the reprint or republication includes copyrighted materials, the credit should also state: "Anyone wishing to make further use of copyrighted material, by itself and apart from this text, should seek necessary permission directly from the proprietors."

Technical Manual
No. 5-810-4
Air Force Manual
No. 88-8, Chapter 3

HEADQUARTERS
DEPARTMENTS OF THE ARMY
AND THE AIR FORCE
Washington, DC, 12 January 1990

COMPRESSED AIR

CHAPTER		Paragraph	Page
CHAPTER 1	GENERAL		
	Purpose	1-1	1-1
	Scope	1-2	1-1
	References	1-3	1-1
	Energy Conservation	1-4	1-1
	Electrical work	1-5	1-1
	Foundations	1-6	1-1
CHAPTER 2	AIR INTAKE		
	Location	2-1	2-1
	Intake temperature	2-2	2-1
	Intake pipe materials	2-3	2-1
	Critical pipe lengths	2-4	2-1
	Intake air filter	2-5	2-1
	Dust and vapors	2-6	2-1
CHAPTER 3	AIR COMPRESSORS		
	Application	3-1	3-1
	Types	3-2	3-1
	Capacity	3-3	3-1
	Multistaging	3-4	3-1
	Number	3-5	3-1
	Location	3-6	3-2
	Automatic warning and shutdown	3-7	3-2
	Vibration limits	3-8	3-2
	Lubrication system	3-9	3-2
	Control system	3-10	3-2
	Sound tests	3-11	3-2
CHAPTER 4	AIR DISCHARGE PIPE		
	Critical pipe lengths	4-1	4-1
	Surge volume	4-2	4-1
	Safety provision	4-3	4-1
CHAPTER 5	AFTERCOOLER AND SEPARATOR		
	Design	5-1	5-1
	Circulating water	5-2	5-1

*This manual supersedes TM 5-810-4/AFM 88-8, Chapter 3, dated 1 December 1982.

CHAPTER 6.	AIR DRYER	Paragraph	Page
	Application	6-1	6-1
	Dryer types	6-2	6-1
	Prefilters and afterfilters	6-3	6-1
CHAPTER 7.	AIR RECEIVER		
	Functions	7-1	7-1
	Determining receiver size	7-2	7-1
	Installation	7-3	7-1
CHAPTER 8.	PIPING		
	Materials	8-1	8-1
	Loss of air pressure due to friction	8-2	8-1
	Piping layout	8-3	8-1
CHAPTER 9.	GENERAL DESIGN REQUIREMENTS AND EQUIPMENT SCHEDULES		
	Design Analysis	9-1	9-1
	Equipment schedules	9-2	9-1
APPENDIX A.	REFERENCES		A-1
			A-2

LIST OF FIGURES

Figure 1-1.	Typical compressed air systems.	1-2
6-1.	Selection guideline for compressed air dryers.	6-2

LIST OF TABLES

Table 2-1.	Effect of intake temperature on air compressor delivery.	2-1
5-1.	Heat dissipation.	5-1
7-1.	Recommended receiver sizes for various compressor capacities.	7-1

CHAPTER 1 GENERAL

1-1. Purpose.

This manual provides guidance for designing low pressure compressed air systems with a maximum design operating pressure of 125 psig, including piping, compressors, aftercoolers and separators, air receivers, and air dryers. Methods for sizing piping are included.

1-2. Scope.

The intention of this manual is to provide criteria to achieve economical, durable, efficient, and dependable compressed air systems to support Army and Air Force facilities. Where special conditions and problems are not covered in this manual, industry standards will be followed. Modifications or additions to existing systems solely for purpose of meeting criteria in this manual are not authorized. Figure 1-1 shows the arrangement of a typical compressed air system.

1-3. References.

Appendix A contains a list of references used in this document.

1-4. Energy conservation.

In selecting the type and number of compressors, the daytime, nighttime, and weekend compressed air demands of the facility must be determined. A single, large air compressor is more efficient and less costly than several smaller units if the demand is fairly constant. If the nighttime or weekend demand is considerably less than the daytime demand, however, the use of several compressors should be considered to handle the total load. At night and on weekends one unit could serve the load with the second as a standby, thereby saving energy. Other energy-saving methods include the following:

a. Compressors.

(1) Install a speed modulator to increase or decrease compressor speed according to compressed air demand when applicable.

(2) Shut down idling air compressors.

(3) Where possible, locate air-cooled compressors where room temperature will not exceed 100 degrees F. Utilize heat from compressors to provide space heating in winter and provide ventilation to remove heat from the plant in summer.

(4) Select an air compressor with a pneumatic load-unload feature that, when fully unloaded, consumes approximately 15 percent of the base load horsepower.

(5) Use waste heat from the oil cooler to heat makeup air, or for building space heating in the winter.

(6) When economically justifiable, use multistage compression with intercoolers.

b. After cooler with separator.

(1) Aftercooler selection should be based on degree of drying required downstream of the aftercooler. Final discharge air temperature of the aftercooler will affect dryer sizing and can reduce both initial and operating costs of compressed air dryers.

(2) Duct air from air-cooled aftercoolers to provide space heating in winter and to remove heat from the plant in summer. Pipe coolant water to recycle heat waste.

c. Filters and dryers.

(1) Improve air quality only to the degree required at the point of use. If air quality requirements differ at various points of use, specify appropriate filters or dryers in applicable branch lines.

(2) Accurately determine the dew point required at each point of use. The type and size of dryer selected will affect operating cost. If the dryer must prevent condensation of moisture in air systems, determine lowest temperature to which piping will be exposed and select dryer to achieve a system pressure dew point 20 degrees F below that lowest temperature. If seasonal temperatures vary widely as from freezing to temperate, select a dryer which allows dew point adjustment.

(3) Room air temperatures will affect drying efficiency. If practicable, locate dryers where ambient temperature will not exceed 100 degrees F.

(4) Select dryer in conjunction with aftercooler so inlet air temperature to the dryer can be as low as feasible. Keep inlet pressure as high as possible. Accurately determine operating temperature and pressure, since even minor changes in either can result in substantial operating costs.

d. Air leakage.

(1) Maximum acceptable air leakage rate for a compressed air system should not exceed 10 percent of the installed system flow rate. Air leaks occur most often at pipe joints, hose connections, and equipment connections; and are usually a result of poor maintenance practices and/or inadequately trained maintenance personnel.

(2) Specification of quality materials and workmanship are a major contribution the designer of a compressed air system can provide for a safe and relatively leakfree air system. In addition, designing the compressed air system with minimum piping and pipe joints, will reduce potential leakage sources.

1-5. Electrical work.

Work will be designed in accordance with TM 5-811-2/AFM, 88-9, Chapter 2.

1-6. Foundations.

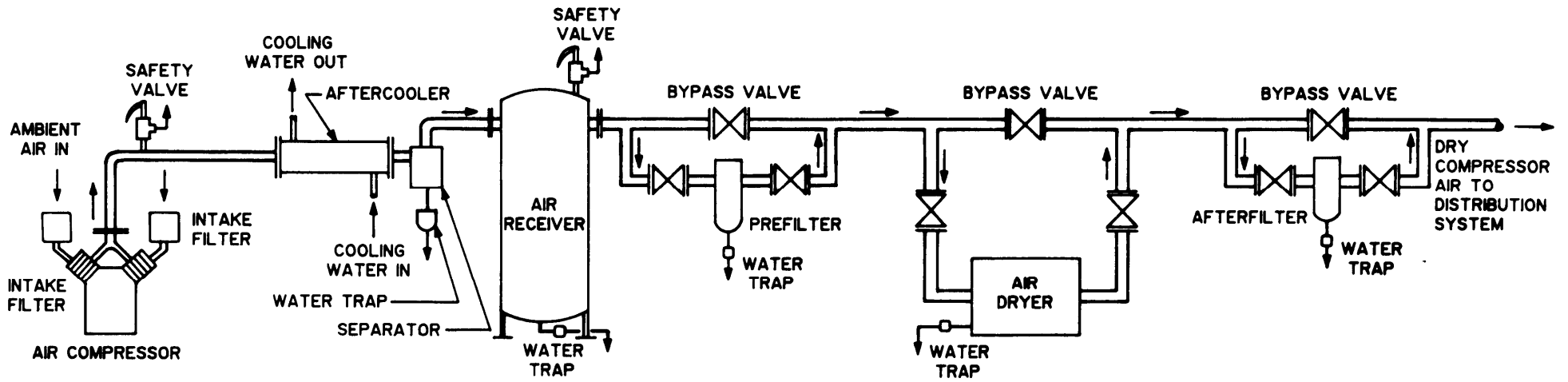

Corps of Engineers

Figure 1-1. Typical compressed air system.

a. A properly designed and constructed compressor foundation performs the following functions:

(1) Maintains the compressor in alignment and at proper elevation.

(2) Minimizes vibration and prevents its transmission to the building structure.

(3) Provides enough mass to support the compressor's weight plus disturbing forces.

(4) Provides for the installation of sufficiently long foundation bolts to insure good anchorage.

b. Concrete foundations must provide a permanently rigid support for the machinery. Where the foundation is exposed to freezing temperatures, its depth should extend below the frost line. Isolating the foundation from any building footings, walls, or floors will help to prevent vibration from being carried into the building structure. TM5-805-4/AFM 88-37 should be consulted for the recommended vibration isolation practices. Each machine requires an independent foundation. Operating platforms must be isolated from the machinery foundations. Drawings will be prepared for compressor foundations, and all conditions surrounding the foundation will be made uniform. The foundation should rest entirely on natural rock or entirely on solid earth, but never on a combination of both. If the foundation substructure rests on bedrock, a vibration damping material should be interposed between the substructure and the bedrock. If a foundation or foundation substructure rests on piling, the piling should be covered with a heavy, continuous, concrete mat. Foundation anchor bolts hold the compressor down firmly and prevent it from sliding laterally.

c. Horizontal and vertical reciprocating air compressors will have a spring-mounted concrete inertia base installed on a concrete foundation block. Limit stops will be provided for seismic considerations. For compressor sizes 25 horsepower and larger, it becomes necessary to engage the services of a foundation specialist to:

(1) Test the ability of the soil to carry the load.

(2) Consider the elastic characteristics of the ground on which the foundation rests, since reciprocating machines exert a dynamic loading as well as a static loading on the foundation. The unbalanced forces of the compressor are available from the manufacturer.

(3) Check wet season and dry season soil characteristics (static loading limits and elasticity).

(4) Determine need for piling, either vertical or batter piles (piles driven at an angle at the foundation ends).

d. Rotary machines have considerably less vibration, and may have a spring-mounted structural steel base supported on a concrete foundation block, with limit stops provided for seismic considerations. Some rotary package compressors may be mounted on existing concrete floors, depending on size and manufacturer's recommendations, requiring only lag bolts to keep the machine in place.

e. Chapter 10, Seismic Design for Mechanical and Electrical Elements, of TM 5-809-10/AFM 88-3, Chapter 13 should

be consulted for seismic considerations.

CHAPTER 2 AIR INTAKE

2-1. Location.

The intake for a compressor will be located either outdoors or indoors, whichever provides better air quality. Elevation of the compressor relative to sea level is required to determine atmospheric pressure and density of intake air. Air quality will be judged by its temperature, humidity, and cleanliness. Indoor sound levels are lower when the air intake is located outside the building, especially with a reciprocating compressor. Where practicable, an outside air intake should be located on the coolest side of the building, at least 6 feet above the ground or roof. For reciprocating units, the intake will be located at least 3 feet away from any wall to minimize the pulsating effect on the structure, and an intake filter silencer or an intake pulsation damper should be provided. A compressor intake must not be located in an enclosed courtyard. Intake pipes must be positioned to prevent entrance of snow or rain water, and must be far enough from steam, gas, or oil engine exhaust pipes to insure intake air that is free of moisture or pollution. Protection by a hood or louvers should be considered when the intake is subject to adverse weather conditions. It is desired that the intake air filter be located on the compressor and piped from the enclosed filter hood to the outside. This method prevents ingestion of foreign material to the internals of the compressor should the piping have a poor joint or other leak upstream of the intake filter.

2-2. Intake temperature.

The density of air varies inversely with its temperature; an increase in delivery of approximately 1 percent is gained for every 5 degrees F reduction of intake temperature. Table 2-1 shows the effect of inlet or initial temperature on air compressor delivery and demonstrates the importance of

locating the air intake at the coolest air source, usually the north side of the building.

2-3. Intake pipe materials.

The inside of intake piping must be smooth and not subject to rusting or oxidation. Rust that flakes off will enter and damage the compressor. Acceptable intake air piping materials include plastic, copper, stainless steel, aluminum, or galvanized steel. On metallic piping, mechanical couplings will be used. Welded joints must be avoided since weld beads can break free, enter, and damage the compressor.

2-4. Critical pipe lengths.

Resonance of intake piping with reciprocating air compressors is prevented by avoiding certain pipe lengths. These are called "critical pipe lengths," and are a function of the air temperature and the speed of the compressor in revolutions per minute (rpm). Critical pipe lengths must be verified with equipment manufacturers.

2-5. Intake air filter.

The selection of the filter type is based on whether the air compressor to be used is lubricated or nonlubricated, and on the quality of ambient air.

a. Viscous impingement filters have an efficiency of 85 to 90 percent of particle sizes larger than 10 microns. This type of filter is acceptable for lubricated reciprocating compressors operating under normal conditions.

b. Oil bath filters have an efficiency of 96 to 98 percent of particles sized larger than 10 microns. This type of filter is more expensive, and for the most part no longer recommended by compressor manufacturers, but may be considered for lubricated reciprocating compressors operating

Table 2-1. Effect of intake temperature on air compressor delivery.

Deg F	Initial Temperatures		Deg F	Initial Temperatures	
	Deg F abs	Relative Delivery		Deg F abs	Relative Delivery
-20	440	1.180	70	530	0.980
-10	450	1.155	80	540	0.961
0	460	1.130	90	550	0.944
10	470	1.104	100	560	0.928
20	480	1.083	110	570	0.912
30	490	1.061	120	580	0.896
32	492	1.058	130	590	0.880
40	500	1.040	140	600	0.866
50	510	1.020	150	610	0.852
60	520	1.000	160	620	0.838

under heavy dust conditions.

c. Dry filters have an efficiency of 99 percent of particles larger than 10 microns. Because of their high filtration efficiency, these filters are the best selection for rotary and reciprocating compressors. They must be used for nonlubricated compressors and whenever air must be kept oil-free.

d. Two-stage dry filters, to provide 99 percent efficiency of particles larger than 0.3 micron, will be used for centrifugal units.

e. With all types of filters, a means of monitoring the air pressure drop through the element must be provided, which indicates element contamination.

2-6. Dust and vapors.

All air compressors are sensitive to dust and airborne vapors which can form adhesive, abrasive, and corrosive mixtures within the compressor. These contaminants build up in rotating parts and can induce excessive wear and mechanical unbalance, thereby damaging the compressor.

CHAPTER 3 AIR COMPRESSORS

3-1. Application.

Whenever it is economically feasible, a central compressed air system will be utilized to serve multiple points of use. The air pressure in the receiver will be in the range of 80 to 125 pounds per square inch gauge (psig). Compressors and all accessories will conform to American Society of Mechanical Engineers (ASME) B19.1 and B19.3, ASME Boiler and Pressure Vessel Code Section VIII, PTC-9 & PTC-10, and Instrument Society of America (ISA) S7.3, as applicable. Oxygen must not be handled in the presence of hydrocarbon lubricants. Where lubricating oils cannot be tolerated at the point of use, oil-free air compressors will be used. Oil-free air is required for such end uses as food handling, medical and dental applications (consult TM 5-838-2 or AFR 88-50, as applicable, and NFPA 99), chemical processing, and instrument air for pneumatic controls. Oil-free air can be obtained by using a centrifugal compressor, which is not lubricated due to its configuration; a water-sealed rotary compressor; or a reciprocating nonlubricated air compressor using carbon or Teflon for piston and packing rings. For isolated cases where oil-free air is required on a compressed air system coalescing filters may be used to remove solids, moisture, and oil from the air stream.

3-2. Types.

An analysis will be made for each compressor selection to insure that the best value is obtained. Comparisons of such items including, but not limited to, brake horsepower (bhp) per 100 cubic feet per minute (cfm), unloaded horsepower, expected compressor life, and expected operation and maintenance costs, should be made between the different types of compressors before final selection is made. The following basic types are available:

a. Reciprocating. Air volumes range up to approximately 6,000 cfm. The need for shielding or baffling structures around the reciprocating compressor to meet noise attenuation requirements requires investigation. These positive displacement compressors are available with oil-lubricated and oil-free cylinders.

b. Liquid sealed rotary. This type of unit provides oil-free, positive displacement, non-pulsating operation. The compressors will have enclosed rotors with conical porting for adjustment of internal clearance. Air volumes range from 50 cfm to approximately 300 cfm. This type of air compressor is recommended for health care facilities.

c. Rotary helical screw. Oil lubricated rotary helical screw compressors have an air volume range from 22 to 3,100 cfm. This type of compressor serves best as a baseload machine. Oil-free rotary helical screw compressors have an air volume range from 400 to 12,000 cfm. Another type of rotary compressor, the oil-free rotary lobe compressor is

available from 100 to 500 cfm. Oil-free rotary screw and rotary lobe compressors can be used for baseload or partial load.

d. Rotary sliding vane. Air volumes range up to approximately 3,000 cfm. Such compressors can be oil-injected, oil-flooded, or oil-free types. This type of compressor has low operating cost, no pulsation, and is free from vibration. This permits installing the compressor directly on the simplest foundation.

e. Centrifugal. Air volumes range from approximately 1,200 cfm to approximately 18,000 cfm. A blowoff silencer is needed for noise control. Centrifugal compressors require no lubrication in contact with the airstream and therefore provide oil-free air.

f. Tank-mounted compressor. A considerable field problem has been experienced with tank rupture at the weldment points. To alleviate the potential problems of tank rupture at weldment points, tank-mounted air compressors are required to be factory-assembled units with tanks constructed in accordance with ASME Boiler and Pressure Vessel Code Section VIII.

3-3. Capacity.

Total air requirement will not be based upon the total of individual maximum requirements, but upon the sum of the average air consumption of air operated devices. Determination of the average air consumption is based on the concept of load factor (the ratio of actual air consumption to the maximum continuous full-loaded air consumption). The Compressed Air and Gas Institute (CAGI) Compressed Air and Gas Handbook explains the procedure for using load factor to determine compressor capacity. After making the calculation, add 10 percent to the estimated consumption for leakage. The total is the compressor capacity required for design. More capacity may be added to allow for future growth of the facility or serviced area over the next 2 years.

3-4. Multistaging.

Multistage compression can be used to reduce power losses associated with the air temperature rise during compression. Also, compression efficiency will be increased using multistaging. The air compressor unit, however, will increase in cost and will be a more complicated machine. Before selecting compressor staging, an economic evaluation should be performed with consideration given to the required air pressure levels and the intended compressor use. When using multistage compression, intercoolers should always be used to improve the efficiency of the air compressor unit.

3-5. Number.

An economic evaluation is necessary to determine whether a central compressed air distribution system or a system of separate compressors located near the point of usage is most cost-effective. Selection of the number of compressors for either situation should be based upon economics and other factors such as system reliability. Seasonal or operational load variations must also be considered. The efficiency of larger compressors is generally higher than that of smaller units, but use of smaller air-cooled units permits savings on water, water piping, and system losses. Multiple units with interconnecting piping give flexibility for maintenance shutdown of one compressor. A smaller air compressor to handle requirements for weekends, holidays, and other low usage times may also be economical.

3-6. Location.

Compressors are to be located in clean, well lighted, and ventilated areas of sufficient size to permit easy access for cleaning, inspection, and any necessary dismantling, such as removal of pistons, wheels, crankshafts, intercoolers, motors, and drivers. Adequate aisle space is needed between items of equipment for normal maintenance as well as for equipment removal and replacement.

3-7. Automatic warning and shutdown.

Air compressor systems will be protected against high temperature, high pressure, low oil pressure, and in the case of centrifugal compressors, excessive vibration. Protective controls will include a fault indicator and a manual reset device.

3-8. Vibration limits.

Compressor manufacturers should be contacted to obtain guidance for establishing representative centrifugal compressor vibration levels.

3-9. Lubrication system.

System design will be in accordance with the manufacturer's recommendations. Lubricant type will depend on the compressor application:

- a. Gravity, splash, or pressure petroleum oil will be used where oil contamination of the compressed air at the point of use is not a problem.
- b. Synthetic liquid lubricants will be used where there is a danger of fire, where the carbonaceous deposits must be reduced, or where lubricant is provided for extended maintenance periods.
- c. Solid lubricants, such as carbon or Teflon piston rings, will be used for oil-free reciprocating compressed air applications.

3-10. Control systems.

Energy can be conserved with a combination of pneumatic cylinder unloading and a manual-off-automatic selector switch on the compressor. When in the manual position,

the compressor loads and unloads to meet compressed air demands. In the automatic position, a time delay relay allows the compressor to operate for a predetermined length of time unloaded, and then stops the unit. An air demand will again start the unit, when needed. For multiple compressor systems, the automatic start/stop sequence should alternate among all compressors.

3-11. Sound tests.

After installation, a sound test must be performed on all compressors and accessories. Sound reading test results must not exceed limitations set by OSHA Standard 1910.95. Measurement of sound emitted from installed and operating air compressors will be in accordance with CAGI Compressed Air and Gas Handbook, Appendix B, "CAGI Pneurop Test Code for the Measurement of Sound from Pneumatic Equipment."

CHAPTER 4 AIR DISCHARGE PIPE

4-1. Critical pipe lengths.

Consideration must be given to critical pipe lengths of the air discharge pipe, and certain lengths must be avoided to prevent resonance. The critical lengths vary with the type and size of air compressor, and can be determined from air compressor manufacturers.

4-2. Surge volume.

Consideration will also be given to surge volume between reciprocating compressors and aftercoolers to minimize vibration and wear in the tubes and tube supports or baffles in the aftercoolers. Pulsation dampers or surge bottles at the compressor discharge will increase the installation cost, however, they may reduce maintenance costs because attenuation of discharge pulsations reduces wear and the potential of tube failures.

4-3. Safety provision.

A safety valve must be provided between a positive displacement compressor discharge and any block valve or other flow restricting device, as well as between the compressor and an internally finned tube aftercooler. This is particularly true with lubricated compressors. If deposits should clog the aftercooler, proper protection would be afforded. Safety valves should be connected directly into the piping at the pressure point it is sensing, without unnecessary additional piping or tubing. Safety valve discharge should be directed away from personnel areas and traffic lanes.

CHAPTER 5 AFTERCOOLER AND SEPARATOR

5-1. Design.

An aftercooler complete with moisture separator to condense and remove water vapor and oil vapor will be used. Aftercoolers should be air-cooled type or water cooled type to best suit installation and economic requirements. Air is cooled to below its dew point in the aftercooler, and the condensed water and oil are then removed by the moisture separator and automatic moisture trap. The aftercooler and separator will be located between the compressor and air dryer or receiver, as close to the compressor as possible. Water cooled aftercoolers should be protected against freezing. As a general rule, a differential of 15 degrees F should be maintained between the temperature of the cooling water entering and the air temperature leaving the aftercooler.

t-rise = degrees F, water temperature rise.

To keep condensation from forming in the cylinder inlet ports, keep the temperature of cooling water entering cylinder jackets 15 degrees F, above the dew point of the incoming air. This can be accomplished by circulating water through the intercooler first, and then piping the same water through the cylinder jackets. An alternate method is to reduce the water supply to the cylinder jackets. The compressor manufacturer should be consulted to verify the cooling water requirements for cooling compressor cylinder jackets.

5-2. Circulating water.

An adequate waterflow through the intercooler, cylinder jacket, and aftercooler is required for cooling the compressor, cooling the compressed air, and for moisture removal. A waterflow sensing control (flow switch) is needed which verifies that sufficient cooling water is flowing before the compressor is allowed to start. Water for the aftercooler for liquid seal rotary compressors should be piped in series with the compressor. Waterflow, prior to startup, for rotary screw compressors and rotary lobe compressors is not required. Piping will be designed to conform to the manufacturer's recommendations. A strainer or filter should be used in the piping system to reduce fouling of the cooler system components.

a. Heat dissipation from intercoolers, cylinder jackets, and aftercoolers is listed in table 5-1.

Table 5-1. Heat dissipation
Btu/minute/bhp total

	Single-Stage	Two-Stage
Intercooler	None	20
Cylinder jacket	15	5
Aftercooler	26	17

Corps of Engineers

b. The amount of cooling water required for intercoolers, cylinder jackets, and aftercoolers may be determined as follows:

$$\text{gpm} = \frac{\text{bhp} \times \text{heat dissipation}}{\text{t-rise} \times 8.33}$$

Where:

- gpm = gallons of water flow per minute.
- bhp = air compressor brake horsepower.

Heat dissipation = value from table 5-1.

CHAPTER 6 AIR DRYER

6-1. Application.

Some compressed air applications require moisture removal in addition to that provided by an aftercooler. Such applications include paint spraying, sandblasting, use of air-operated tools and devices, pneumatic automatic temperature controls, lines run outside in cold or subfreezing locations, and lines passing through cold storage rooms.

6-2. Dryer types.

Supplementary moisture removal requires additional equipment, higher first cost, and higher operating cost for all drying methods. In determining overall costs, the initial purchase price should be weighed against operating and maintenance costs. Figure 6-1 illustrates the relative costs for the various types of dryers, and presents selection guidelines. In determining the type of dryer to be used for a given application, drying requirements, flow, pressure, inlet temperatures, and the pressure dew point must be accurately determined. The dryer that meets these requirements most economically and efficiently should be selected. The various drying methods are as follows:

a. Refrigeration. Refrigeration dryers remove moisture from compressed air by cooling the air in a heat exchanger. This condenses and removes the moisture from the airstream and produces an operating pressure dew point at the dryer outlet in the range of 35 to 39 degrees F. By adjusting the refrigeration unit operating parameters, these units can produce pressure dew points of 50 degrees F. Higher dew points are available in either direct refrigeration or chiller-type design.

b. Twin-tower regenerative. Regenerative dryers utilize nonconsumable desiccants to remove moisture from compressed air. Inlet air is automatically cycled between two desiccant towers, one absorbing moisture from the inlet air while the other is being regenerated. This method of regeneration includes the following dryer classifications:

(1) Heatless desiccant regeneration passes a quantity of dried (purge) air through the offstream bed. No external heat is applied. This type, with a field-adjustable purge control should be selected so that purge rate (and therefore pressure dew point) can be adjusted to accommodate seasonal variations in ambient temperatures, thereby reducing operating costs. Heatless dryers are capable of providing minus 150 degrees F, pressure dew point. Maintenance costs are low since there are few moving parts. With adequate prefiltering to remove oil, desiccant replacement requirements are minimal.

(2) Heat regenerative dryers utilize heat from an external source (either electric or steam) in conjunction with purge

air to regenerate the offstream tower. By reducing the amount of purge air required for regeneration, the heat regenerative dryer operating costs are lower. High regenerative temperatures, however, are damaging to equipment and desiccant, so any savings in operating costs can be outweighed by the costs of maintenance and downtime.

c. Deliquescent. Deliquescent (salt pellet) dryers and ethylene glycol stills are included in this manual for comparison and general information purposes only, and will not be used because of their high operating cost and their limited effect on pressure dew point. These types of dryers carry over salt or glycol into the airlines, resulting in corrosion and potential damage to controls and tools. Glycol also reacts with certain constituents of the air (mainly carbon dioxide and carbon monoxide) to form corrosive compounds that attack piping and equipment.

6.3. Prefilters and afterfilters.

Consideration should be given to providing a prefilter upstream of the air dryer and an afterfilter downstream of the air dryer. A prefilter may be required to remove compressor carry-over oil and other undesirable particles from the air prior to the air entering the air dryer. This filter can extend the life of the air dryer and reduce air dryer maintenance costs. An afterfilter should be considered to protect the downstream piping system and equipment from impurities and undesirable particles added to the air as a result of passing through the air dryer. Air dryer manufacturers should be consulted for recommendations and selection of prefilters and afterfilters for specific air quality requirements.

Type of Dryer	Pressure Dew Point Range	Typical Applications	Initial Cost	Operating Cost	Remarks
DELIQUESCENT					
	12-20°F below inlet temperature	Protection against condensation in indoor air lines.	Lowest	Low to moderate	Causes high maintenance of downstream equipment due to salt solution in air lines.
REFRIGERATED					
	Above 33°F	General plant air, air-operated tools, instruments; materials conveying.	Low	Lowest	Most widely used type of air dryer because of its inherent reliability and low cost factor.
TWIN-TOWER REGENERATIVE					
Heatless Desiccant	Below 33°F (down to minus 150°F)	Outside air lines; chlorine padding; manufacturing processes requiring very dry air such as assembling electronic components and making urethane foam.	Low to moderate	Highest	Inefficient operation due to high purge rate.
Heat Regenerative			Moderate to high	Moderate to high	Minimum air waste for high flow, low dew point applications.

Reprinted with permission of Deltech Engineering Inc.,
Century Park, New Castle, Delaware

Figure 6-1 Selection guidelines for compressed air dryers.

CHAPTER 7 AIR RECEIVER

7-1. Functions.

The air receiver dampens pulsations entering the discharge line from the compressor; serves as a reservoir for sudden or unusually heavy demands in excess of compressor capacity; prevents too frequent loading and unloading (short cycling) of the compressor; and separates moisture and oil vapor, allowing the moisture carried over from the aftercoolers to precipitate. Air receivers shall be constructed in accordance with ASME Boiler and Pressure Vessel Code Section VIII.

7-2. Determining receiver size.

After the air compressor capacity has been established, the appropriate receiver size can be determined. Table 7-1 lists the sizes of air receivers in common use and the compressor capacities recommended for each receiver size, at pressures of 40 to 125 psig.

Table 7-1. Recommended receiver sizes
for various compressor capacities

Compressor Capacity (cfm) (40-125 psig Operating Press.)	Receiver Nominal Diameter (in)	Receiver Shell Length (ft)	Receiver Volume (ft ³)
45	14	4	4-1/2
110	18	6	11
190	24	6	19
340	30	7	34
570	36	8	57
960	42	10	96
2,115	48	12	151
3,120	54	14	223
4,400	60	16	314
6,000	66	18	428

Corps of Engineers

7-3. Installation.

The receiver will be installed on an equipment pad to keep it dry. Adequate space around the unit is needed for draining, inspection, and maintenance. When the receiver is located outside, the safety valve and pressure gauge will be installed indoors to prevent freezing, and the associated outdoor piping will be heat traced and arranged to drain back to the receiver. Where automatic condensate traps are used with receivers located outdoors, the traps will be located indoors and the outdoor piping heat traced or the traps and piping located outdoors will be provided with electric heat tape to protect them from freezing.

CHAPTER 8 PIPING

8-1. Materials.

a. Steel compressed air piping will be Schedule 80 for sizes 2 inches and smaller and Schedule 40 for sizes over 2 inches and will be galvanized or black steel or stainless steel. Copper compressed air piping or tubing will be Type K or Type L. Fiberglass reinforced plastic (FRP), as specified in Mil. Spec. MIL-P-28584, may also be used within the following limitations:

(1) 150 psig maximum pressure, up to 200 degrees F.

(2) 75 psig maximum pressure, up to 250 degrees F.

Pipe fittings will be galvanized or black steel or stainless steel, to match piping used. When copper pipe or tubing is used, brazed joints will be used for connections. Brazing filler metals with melting temperatures between 1,000 degrees F and 1,600 degrees F will be used. Soldered joints should not be used.

b. Thermoplastic piping systems for transport or storage of compressed air will not be allowed. Safety records show that leaks in these types of pipe (when used for compressed air service) have caused the pipe to rupture, causing serious injury to personnel and/or property damage.

8-2. Loss of air pressure due to friction.

The loss of pressure in piping is caused by resistance in pipe, fittings, and valves, which dissipates energy by producing turbulence. The piping system will be designed for a maximum allowable pressure drop of 5 percent from the compressor to the most distant point of use. The Darcy formula and nomograph shown in the Crane Co. Technical Paper No. 410 may be used to determine pressure drop through pipe, valves, and fittings.

8-3. Piping layout.

Where possible the piping system should be arranged as a closed loop or "ring main" to allow for more uniform air distribution to consumption points and to equalize pressure in the piping. Separate services requiring heavy air consumption and at long distances from the compressor unit should be supplied by separate main airlines. Pipes to be installed parallel with the lines of the building, with main and branch headers sloping down toward a dead end. Traps will be installed in airlines at all low points and dead ends to remove condensed moisture. Automatic moisture traps used for this purpose are effective only when the air has been cooled and the moisture has precipitated. Branch headers from compressed air mains will be taken off at the top to avoid picking up moisture. When an isolation valve, or other flow restricting device, is placed in the discharge line between the compressor and aftercooler or receiver, a safety valve or valves will be placed in the pipeline between them. The safety

valve or valves will have a total capacity sufficient to handle the entire output of the compressor. (If no safety valve is used, and the isolation valve is closed upon starting, or anytime during compressor operation, sufficient pressure may be built up which could cause injury or damage.) A strainer or filter and a lubricator must be provided in piping that serves tools. Flexible connectors, such as flexible metal hose, will be used to connect the discharge piping system to the air compressors. Where air quality downstream of the compressor, receiver, and dryer is not assured for the end use, the required additional filtration will be provided at the point of use.

CHAPTER 9 GENERAL DESIGN AND EQUIPMENT SCHEDULES

9-1. Design analysis.

The following items will be considered in the design analysis:

- a. Application (hospital, industrial, etc.).
- b. Maximum operating pressure required.
- c. Location of air requirements in buildings.
- d. Air usage, continuous or intermittent demand.
- e. Operating pressure dew point requirements.
- f. Air filtration needs at points of use.
- g. Need for oil-free air.

d. Air dryer.

- (1) Type.
- (2) Capacity (cfm and operating pressure).
- (3) Dew point temperature entering and leaving.
- (4) Ambient temperature (degrees F).
- (5) Volts, phase, hertz (if applicable).
- (6) Accessory list.
- (7) Spare parts list.

9-2. Equipment schedules.

Equipment schedules will be shown on the drawings, including the following:

- a. Air compressor.
 - (1) Capacity (cubic feet of free air per minute).
 - (2) Discharge pressure, psig.
 - (3) Minimum motor horsepower.
 - (4) Volts, phase, hertz.
 - (5) Accessory list.
 - (6) Spare parts list.
- b. Air receiver.
 - (1) Capacity (cubic feet of volume).
 - (2) Design pressure, psig.
 - (3) Type (horizontal) (vertical).
 - (4) Diameter (feet).
 - (5) Length (feet).
 - (6) Accessory list.
 - (7) Spare parts list.
- c. Aftercooler-separator.
 - (1) Water cooled.
 - (a) Capacity (cfm and psig).
 - (b) Dew point temperature entering and leaving.
 - (c) Length (inches), diameter (inches).
 - (d) Cooling water.
 - Gpm flow.
 - Temperature in.
 - Temperature out.
 - (e) Accessory list.
 - (f) Spare parts list.
 - (2) Air cooled.
 - (a) Capacity (cfm and psig).
 - (b) Compressed air inlet temperature entering after-cooler.
 - (c) Approach temperature.
 - (d) Ambient air temperature.
 - (e) Minimum fan motor horsepower.
 - (f) Volts, phase, hertz.
 - (g) Accessory list.
 - (h) Spare parts list.

APPENDIX A REFERENCES

Government Publications.

Departments of the Army, Air Force, and Navy.
AFR 88-50

TM 5-805-4/AFM 88-37

TM 5-809-10/AFM 88-3,
Chap. 13

TM 5-811-2/AFM5
88-9, Chap.2

TM 5-838-2

Military Specification (Mil. Spec.)
MIL-P-28584A

Occupational Safety and Health Administration (OSHA).

Bureau of National Affairs Inc., Washington, DC 20037
1910.95

Nongovernment Publications

American Society of Mechanical Engineers (ASME).
22 Law Drive, Box 2350, Fairfield, NJ. 07007-2350

B19.1-1985
& B19.1a-1985
B19.3-1986

Boiler and Pressure Vessel Code and Interpretation:
Section VIII

PTC 9-1970 (R 1985)
with 1972 Errata)

PTC 10-1965 (R 1986)

Compressed Air and Gas Institute (CAGI), 1230 Keith
Building, 1621 Euclid Avenue, Cleveland, OH 44155
Compressed Air and Gas Handbook, 4th Ed., 1973

Crane Company, 300 Park Avenue, New York, NY 10022
Technical Paper No.
410

Instrument Society of America (ISA), P.O. Box 3561, Durham,
NC 27702

Criteria for Design and Construction
of Air Force Health Facilities

Noise and Vibration Control for
Mechanical Equipment.

Seismic Design for Buildings.

Electrical Design: Interior
Electrical System.

Army Health Facility Design.

Pipe and Pipe Fittings, Glass
Fiber Reinforced Plastic, for
Condensate Return Lines.

Occupational Noise Exposure

Safety Standard for Air
Compressor Systems
Safety Standard for Compressors
for Process Industries

Pressure Vessels, Division I
(1986; Addenda:
Dec 1986; Dec 1987)
Displacement Compressors,
Vacuum Pumps and Blowers
Compressors and Exhausters

Flow of Fluids Through Valves,
Fittings and Pipe (Updated 1982)

S7.3-1975 (R 1981)

Quality Standard for Instrument
Air

National Fire Protection Agency (NFPA), Batterymarch Park.
Quincy, MA 02269
99-1987

Standard for Health Care
Facilities

The proponent agency of this publication is the Office of Chief of Engineers, United State Army. Army users are invited to send comments and suggest improvements on DA Form 2028 (Recommended Changes to Publications and Blank Forms) directly to HQUSACE, CEMP-ET, WASH DC 20314-1000.

By Order of the Secretaries of the Army, the Navy, and the Air Force:

Official:

CARL E. VUONO
General, United State Army
Chief of Staff

WILLIAM J. MEEHAN II
Brigadier General, United States Army
The Adjutant General

Official

LARRY D. WELCH, *General, USAF*
Chief of Staff

WILLIAM O. NATIONS, *Colonel, USAF*
Director Information Management
and Administration

Distribution:

Army: To be distributed in accordance with DA Form 12-34B, requirements for Compressed Air.

Air Force: F